

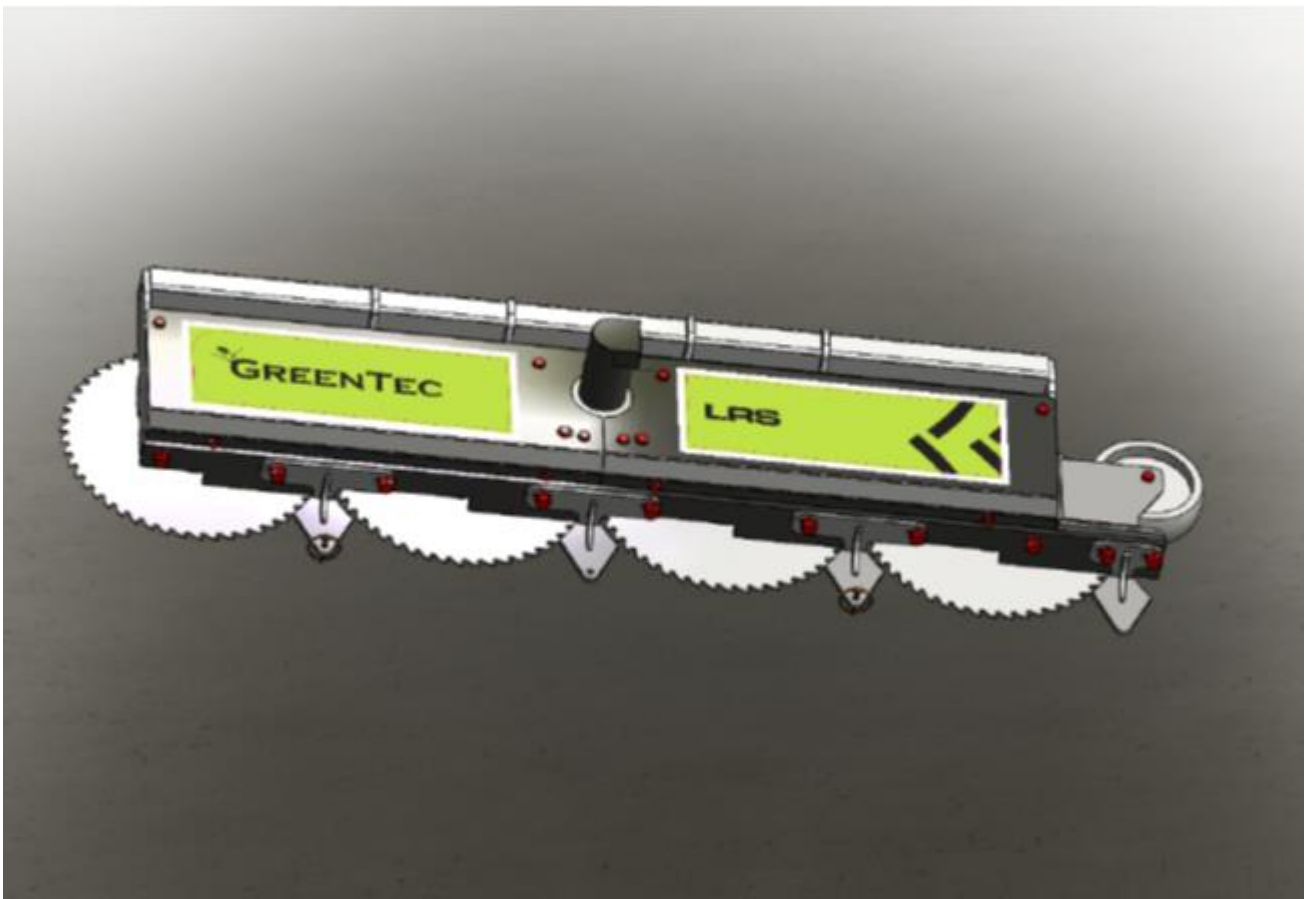

LRS 1402

QUADSAW

Hand book



6. Edition Oct. 2015

©Spearhead Machinery Limited

Contents

Contents

<i>Introduction</i>	3
<i>Important</i>	4
<i>EU Declaration of Conformity</i>	5
<i>Mounting the Quadsaw</i>	6
<i>Operation / Introduction</i>	7
<i>Maintenance</i>	7
<i>Driving recommendations</i>	7
<i>Belt diagram</i>	8
<i>Correct belt adjustment</i>	10
<i>Technical data and description of working tool</i>	11
<i>Safety</i>	12
<i>Noise measuring</i>	13
<i>Supplier information and CE-declarations</i>	13
<i>CE-declaration</i>	13
<i>Warnings, ban and directions.</i>	13
<i>Disassemble</i>	13

Introduction

Dear customer!

GreenTec LRS 1402 Quadsaw is designed with a background of 20 years of experience with cutting-tool technology, and building of special machines. They are made from the latest technology and recognized safety technical regulations, standards and regulations.

It is our goal to make a product available in such a way that, neither during transit by further processing and compilation process or the subsequent use is damage.

This manual contains information and instructions there are important and useful for the preservation of LRS 1402 Quadsaw reliability, dependability and value. Read this manual carefully and pay particular attention to the instructions for the avoiding of damage.

The content also makes you familiar with connectivity, use, care and maintenance. And then it helps to prevent injuries.

We hope, you are happy with your new LRS 1402 Quadsaw.

Best regards:



John Christensen
Sales Director, GreenTec A/S

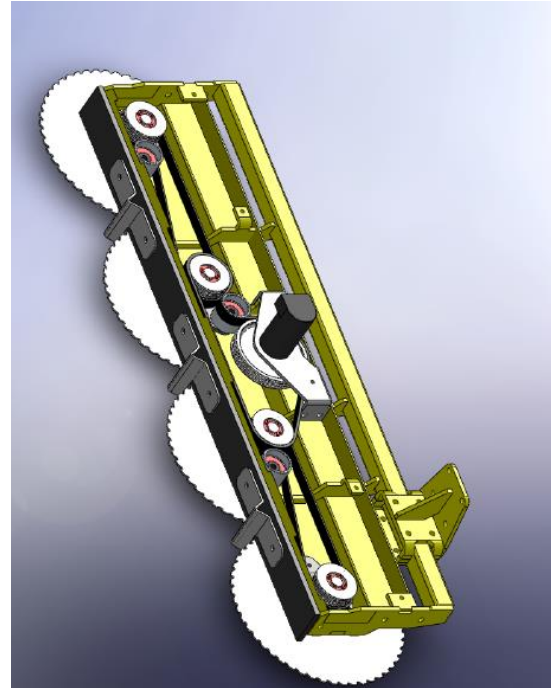

Important

Please ensure that this manual is handed to the operator before using the machine for the first time. The operator must fully understand the contents of this manual before using this machine. (If the machine is resold the Manual must be given to the new owner.)

Please, fill out the following information. It is practical information that is useable when ordering spare parts.

Serial number:

Delivery date:

Dealer name :

Address:

Tel. / Fax No.:

GreenTec A/S
Merkurvej 25
Dk-6000 Kolding
Tel: +45 7555 3644
Fax: +45 7555 4243
E-mail: info@greentec.eu
Http: www.greentec.eu



Merkurvej 25, DK-6000 Kolding, Denmark

EU Declaration of Conformity

Adapted EEC directive
EG Guideline 2006/42/EF, 89/392/EEC & 98/37/EC

We, **GreenTec A/S**, Merkurvej 25, 6000 Kolding, hereby declare that in terms of its design, method of construction and our execution thereof, the item of machinery described below complies with the basic health and safety regulations of the respective EU Directives.

- DS/EN ISO 12100 3rd edition 2011. Safety of Machinery – General principles for design – Risk assessment and risk reduction.
- DS/EN 953+A1 4th edition 2010. Safety of Machinery – Guards-General requirements for the design and construction of fixed and movable guards.
- DS/EN ISO 4413 1th edition 2010. Hydraulic fluid power – General rules and safety requirements for systems and their components.

Produkt: GreenTec LRS 1402

Produktkode: 9991402

Serienummer: S 58375

Type: Quadsaw



The EC Declaration only applies if the machine stated above is used in accordance with the operating instructions.
on behalf of

Date: 22.10.2014

Signature: 
John Christensen Sales Director

Mounting the Quadsaw

- The blade is mounted, so the direction of rotation of the saw goes down (Fig. 1).
- Saw is mounted in such a way, that the blade runs straight in the driving direction (Fig. 2).
- Mount the hydraulic hoses so the blades are running in correct direction. The drain hose shall go in free to the hydraulic oil tank. Pressure (P) and Return (T) mounting as shown in (Fig. 1).
- Check the hydraulic system for leaks.
- First time the machine is used. Measure the blades rpm 4000 by 25 L/min. Holding this speed is important for the best optimum performance.

Fig. 1.

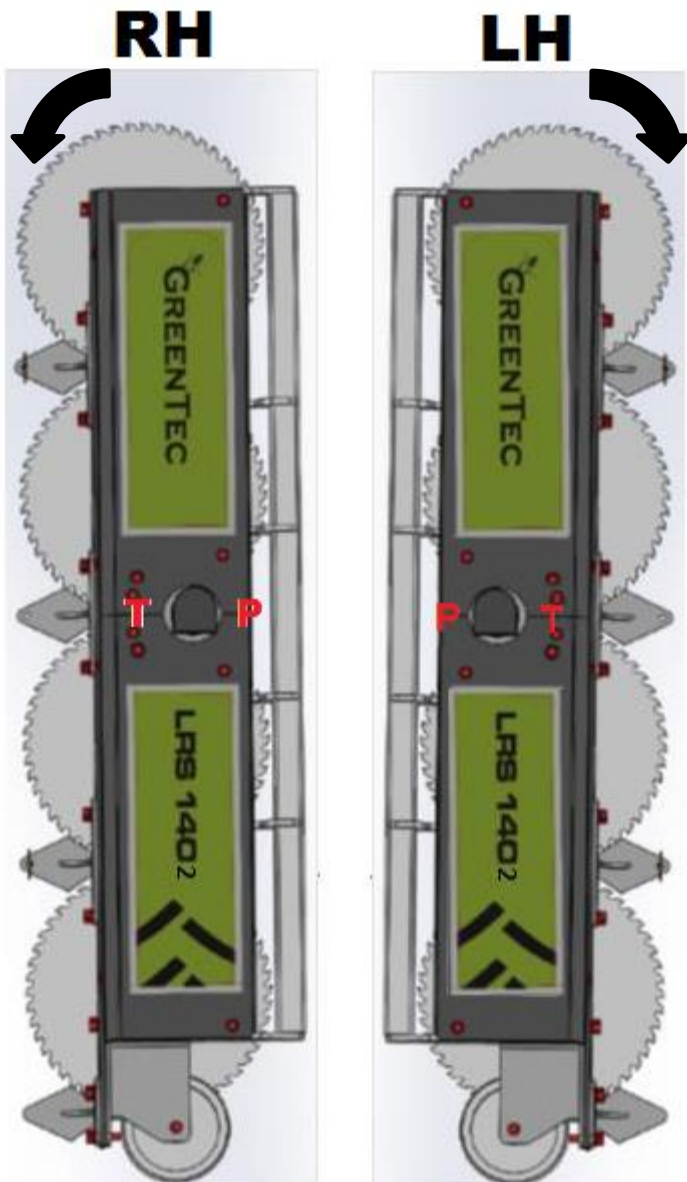
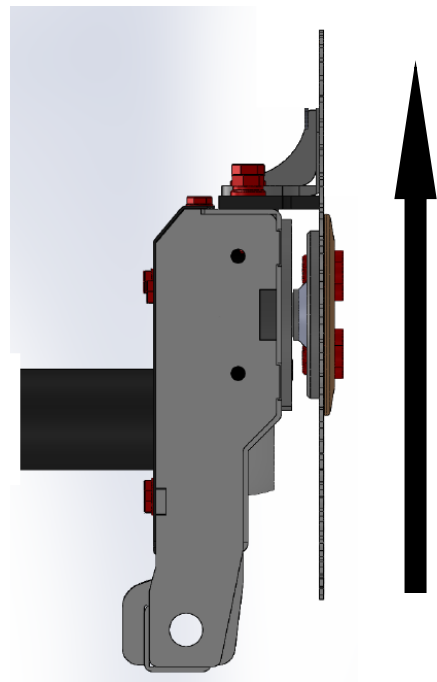

Fig. 2.



Operation / Introduction

The Quadsaw is used for cutting branches and trees up to a max. diameter of 100 mm without the branches being torn.

Branches with a diameter over 40 mm, must be cut one of the time.

Vertical cutting is allowed up to a 45 degree angle. Horizontal cutting is possible on hedges with a width up to 80 cm. and a branch diameter up to 20 mm. Thicker branches might stop the blades and get stuck in the machine.

Maintenance

- After 2 hours driving tighten everything. Allen-screws for the saw blades with 40 Nm.
- After 10 hours work all bolts, screws and retightened
- All bolts shall be retightened / checked every 8 hour.
- Plastic rail is adjusted down to the blades, with a distance of 1 mm. Is there more than 5 mm intervals, replace the list. Branch deflectors adjusted as closely as possible into the saw blades, without touching the blades.
- Dismount protection plate to the belts, and clean the house for dirt.
- Inspect, and if necessary adjust the belts. (See belt diagram)
- After inspection or service ALL protection plates and guards must be replaced.

Driving recommendations

Starting and stopping the saw shall always be at lowest pto. rpm.

It is recommended to travel at a slow forward speed when starting work in order to obtain and keep the recommended rpm of the blades. Adjust the angle of the saw to approx 90 degrees in relation to the branches. If a thick branch is approaching the branch reflectors , the working height must be adjusted for the branch to hit the saw blades straight on.

If small branches or other unwanted material get stuck in the blades, the machine must be stopped and cleaned.

Always ensure that the blades are running vertical related to the direction of the travel. This will prevent the blades from bending too much.

Belt diagram

It is utmost importance that the belts are correctly mounted and tightened. When new belts are mounted they must be tensioned to 370 Nm.

After 3-5 working hours the belts may have slackened and must be checked.

BEWARE!! The tension has now changed. The belts is tightened to 330 Nm.

Contact GreenTec's After Sales Department if you have any questions. We might help you with a piece of good advice.

RH

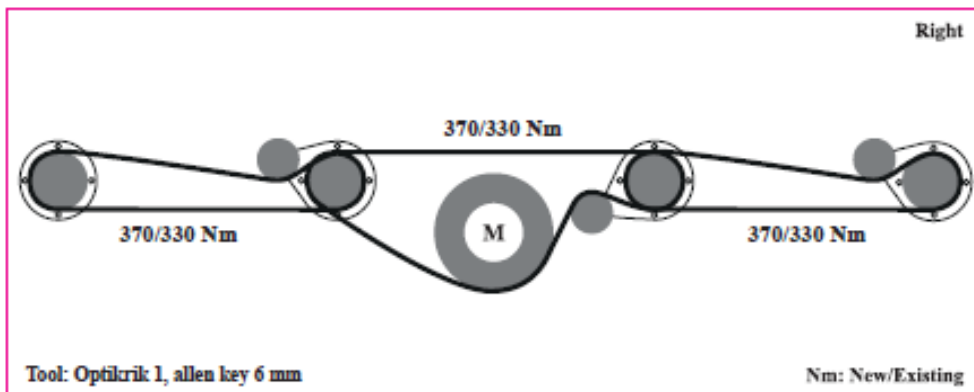

LH

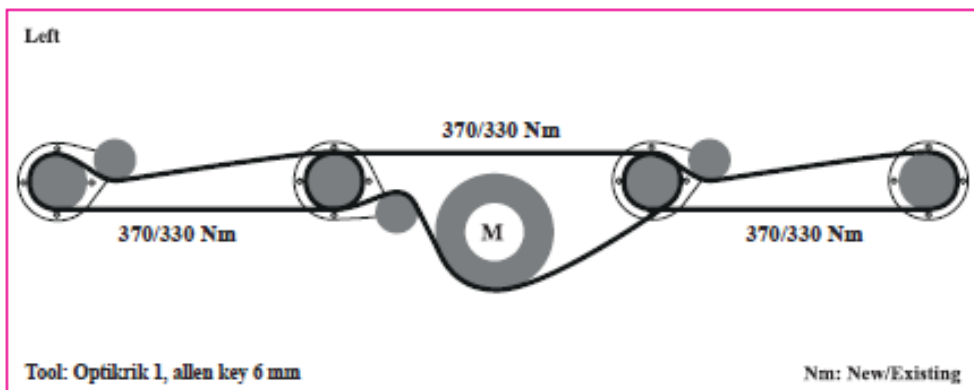

Tool for belt tension control. OPTIKRIK I. Part no. 140155.0

Correct belt adjustment

See also "Belt Diagram" for more information.

NOTE!! After adjusting, turn the blades some rounds and then control again.

The adjustment is similar on LRS1401 and 1402

Recommended tools
Belt measure "Optikrik I"
13 mm top
Allenkey 6 mm (Use a top, long type)
Ratchet with short extension
Gloves

Remove 5 bolts for each lid

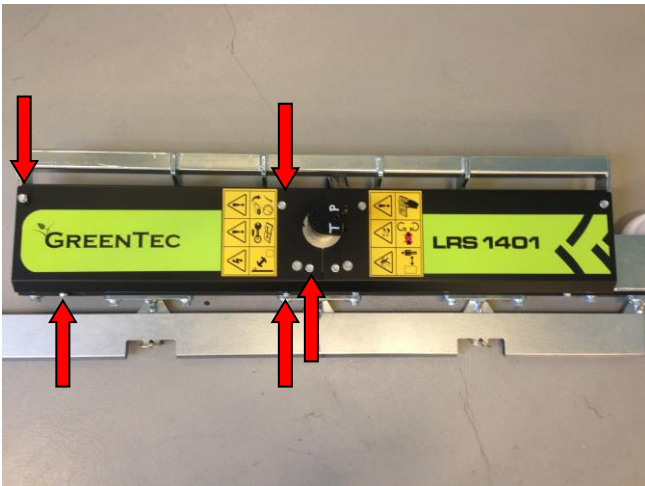

There are 3 Belt tensioners. 1 for each belt

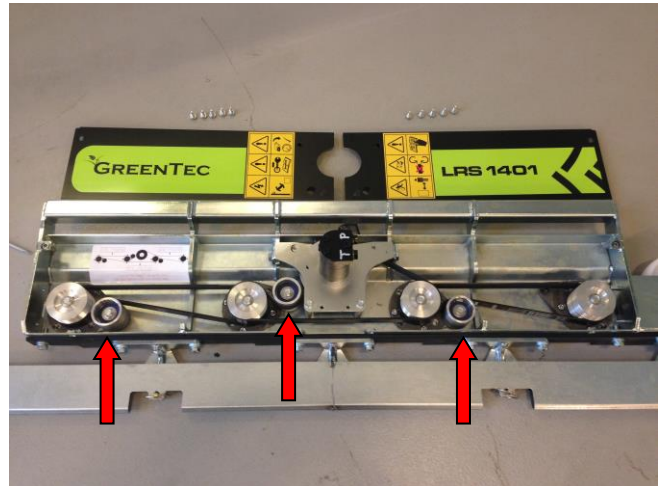

Loosen the 4 Allen screws. Adjust to correct Nm

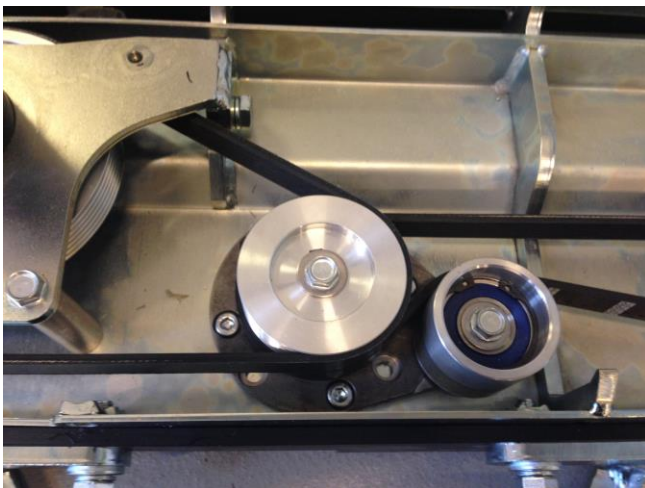

Technical data and description of working tool

- Quadsaw for mounting, on hydraulic hedge cutters.
- Frame with 4 shafts, for mounting the saw blade Ø 340 mm.
- Drift of each shaft by rib ribbon belts, the entire operation is done by the hydraulic powered motor. Branch deflectors are placed between the blades.
- The Quadsaw is supplied with a special bracket enabling mounting on various vehicles / machines.
- The drive belt is like the supporting part on the carrying frame entirely covered.

LRS 1402	
Working width	1400 mm
Blade speed	4000
Blade diameter	340 mm
Teeth per blade	60 stk.
Material	Hardened metal with special teeth HM precision blade.
Performance	5 – 100 mm branch diameter.
Application	Vertical
Oil flow 11,2 cc	25 L/min. Max. 200 bar (Twiga 120 = 100 bar)
e. g. Twiga 320	350 Pto. rpm.

Safety

- ⊗ Never operate the machine with other people present, as it is possible for debris to be thrown from the saw blades in all directions.
- ⊗ Always ensure all cab safety guards are in place and all tractor windows are closed. Never allow an inexperienced person to operate the machine without supervision.
- ⊗ Never allow children to play or around the machine at any time.
- ⊗ Never attempt any maintenance or adjustment without first disengaging the pto / hydraulic pump, lowering the head to the ground, stopping the tractor engine and applying the tractor parking brake.
- ⊗ Before leaving the tractor cab always ensure that the saw head is firmly on the ground, no weight is on the tractors hydraulics and blades have stopped spinning.
- ⊗ Never stop the engine, when the power transmission is engaged.
- ⊗ Always check that all guards are properly fitted, check there are no damaged or loose parts.
- ⊗ Always drive with the correct rotations of the blades (see specifications).
- ⊗ Maximum oil pressure of 200 bar in the hydraulic hoses.
- ⊗ Never transport without the blade protection guards mounted.
- ⊗ Always inspect work area for wire, steel posts, large stones and other dangerous materials. If such items are found remove them.
- ⊗ Never drive with wire or the like. wrapped around the blades / knife axles. Stop immediately and remove the unwanted material.
- ⊗ Never attempt to use the machine for any purpose other than that it was designed for.
- ⊗ Ensure that all warning labels are always visible and that they are not damaged, defaced or missing.
- ⊗ PTO must never be connected during transport.

Noise measuring

Noise measuring has been made on the machine during normal working conditions at GreenTec A/S in Denmark, with a Elma 1350B Noise measurer, ICE 651 type II.

- The energy A-weighted Sound pressure is lower than **84 dB (A)**.

The test has been done in a distance of 1 meter from the machines critical noise maker and in a height of 1.5 meters over the ground.

Supplier information and CE-declarations

Company name	: GreenTec A/S
Address	: Merkurvej 25
Mail code /City	: DK-6000 Kolding
Land	: Danmark
Tlf	: +45 75 55 36 44
E-mail	: info@greentec.eu

CE-declaration

Producent	: GreenTec A/S
Tlf	: +45 75 55 36 44
E-mail	: info@greentec.eu
Machine No.	: LRS 1402
Delivery date	: _____
Delivery year	: 2015

Warnings, ban and directions.

Warning!

Never attempt any maintenance or adjustment, without first disengaging the pto / hydraulic-pump.

Warning!

Only authorised personal must do maintenance work on the equipment.

Direction!

Read this manual carefully before using the machine.

Disassemble

Machine disengaged from all connections. Removal of the parts must be done according to national and EU legislation. To ensure the most environmentally friendly removal, the machine must be disassembled and the parts separated as following:

Category:	Example of parts:
Rubber and plastic	Hoses, plastic strip.
Technical components	Pumps, hydraulic hoses.
Pure metal	Plates, pipes, guard.