

QUADSAW

LRS 1602



PARTS

UK

4th Edition 2018

 **GREENTEC**

Cutting Edge Technology

IMPORTANT INFORMATION

GreenTec LRS 1602

PARTS

4. Edition – Januar 2019

NOTICE: Please ensure that this manual is handed to the operator before using the machine for the first time. If the machine is resold, the Parts list must be given to the new owner!

The information contained in this Parts list is correct at the time of publication. However, in the course of constant development, changes in specification are inevitable. Should you find the information given in this book different to the machine it relates to please contact the “After Sales Department” for advice.



CONTENTS

CONTENTS	4
INTRODUCTION	5
USEFUL INFORMATION	6
ORDERING PARTS	6
SPARE PARTS	8
Main frame GT	8
Main frame PL	10
Motor	12
Blade shaft	14
Option Bladerotor kpl. OPTE 4227	15
Secondary tensioning system	16
Primary tensioning system	17
Stickers	18

INTRODUCTION

Dear customer!

Your new GreenTec machine is constructed with background in more than 20 years experience with tractor mounted machines to maintenance of green areas. This machine is produced by the latest technology and recognized safety regulations, standards and regulations.

We want to make a product available in such a way, that neither the use of the machine during transportation or maintenance of the machine causes any damage or misunderstandings.

This parts list contains information that are important and useful for maintaining your GreenTec machine's reliability, dependability and value.

You are welcome to visit our website www.greentec.eu - where the login via the dealer's access gives you the latest updates on instructional and part books on our entire product range.

We hope, you will be pleased with your new GreenTec machine.



Best regards,

A handwritten signature in blue ink, appearing to read "John Christensen".

John Christensen
Sales Director GreenTec A/S

GreenTec's vision is to develop and sell quality machines for the maintenance of green areas, including in agriculture, in industry, at airports and in the local sector. Through innovative product development, we will strive to become a leader in our field.

All machines are developed in a simple and functional design in close cooperation with dealers and end users. It is our goal to cover every need in the market segment with preferably 2 different solutions. In-depth analysis of requirements and serious advice to the customer is offered the best solution, where individual needs can be met through the modularity of the product program.

Our goal is also to offer the best possible after sales service, and a quick and efficient spare parts supply.

USEFUL INFORMATION

Before using the machine for the first time, it's the seller's responsibility that the buyer is given this parts list. If the machine is resold, the parts list must be transferred to the new owner.

Please fill out the list below to ensure that the necessary information is at hand when ordering spare parts etc.

Serial No

Delivery date

Dealer

E-mail

Tel.



Merkurvej 25
DK 6000 Kolding
Denmark
Tel: +45 75553644
Email: info@greentec.eu
web: www.greentec.eu
Opening hours: Mon-Fri 8-16

ORDERING PARTS

When ordering parts please refer to your parts list to help your dealer with your order.

- Part number and quantity
- Description
- Machine model number
- Serial number of the machine
- Delivery instructions (e.g. next day).

Delivery is normally via carrier direct to your dealer. Please check with your dealer for stock availability and arrangement of dispatch. Ensure you or your dealer has sufficient cover for parts requirement outside factory hours.

Important Note

The information contained in this manual is correct at the time of publication. However, in the course of constant development, changes in specification are inevitable. Should you find the information given in this book different to the machine it relates to, please contact the “After Sales Department” for advice.

Key:

(LH) = Left hand saw
(RH) = Right hand saw

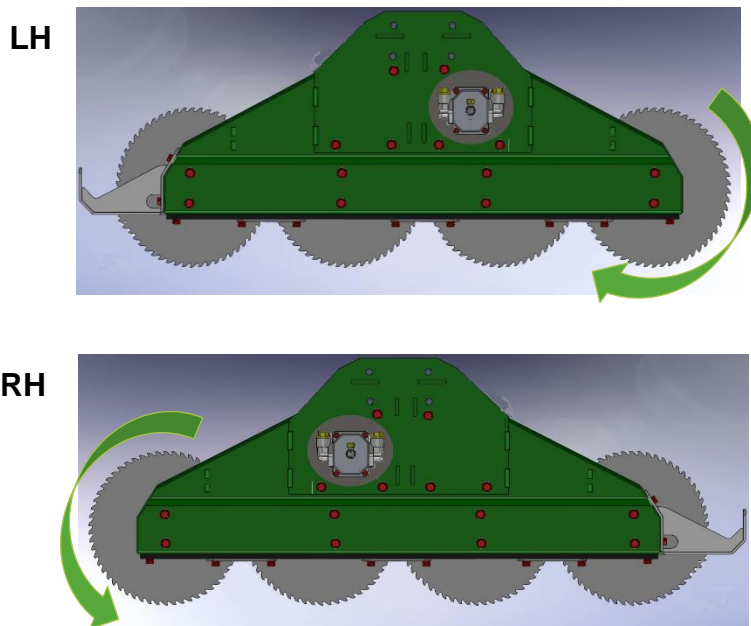

SPARE PARTS

Main frame GT

31

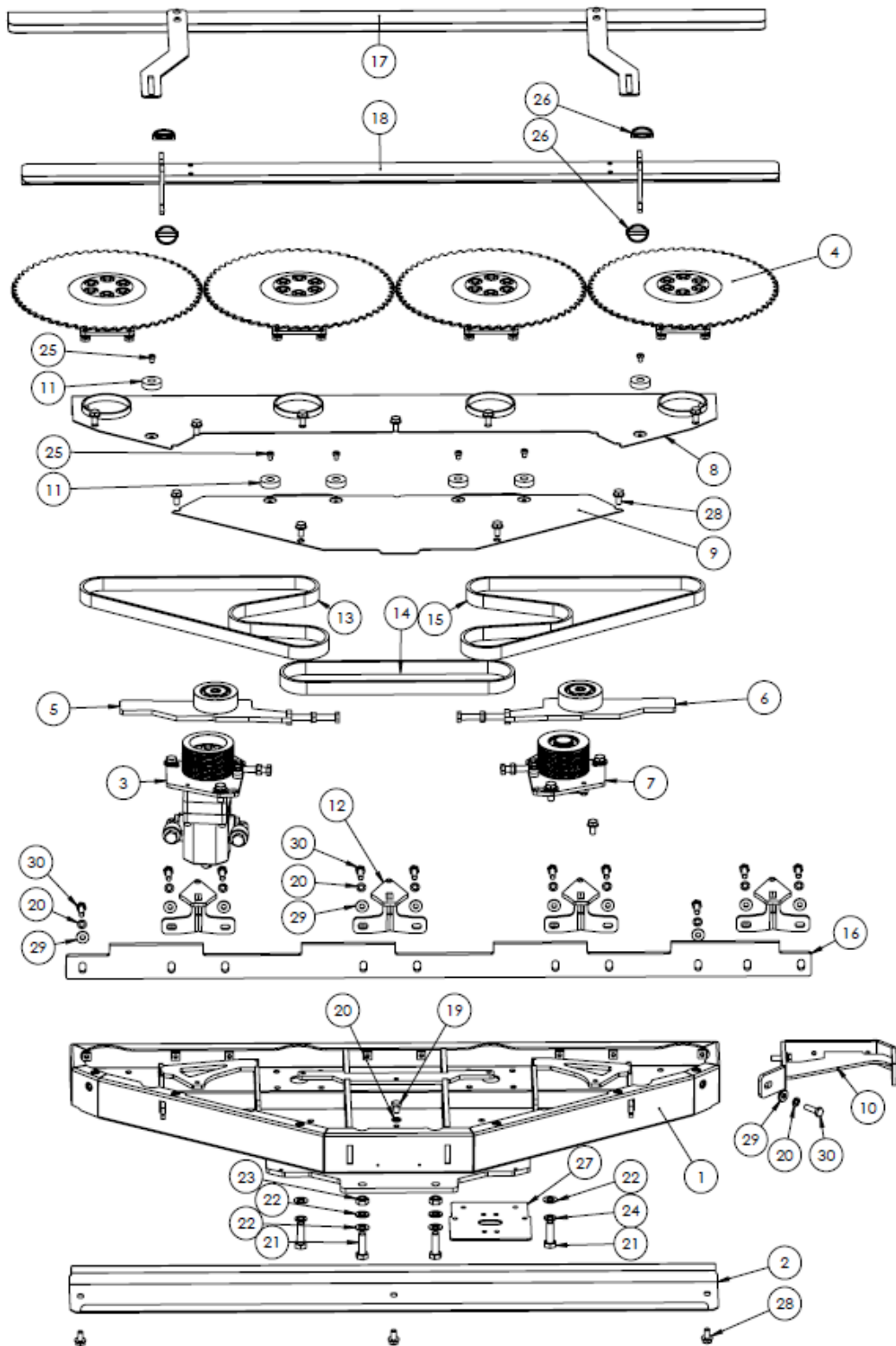

ITEM NO.	PART NUMBER	DESCRIPTION	QTY.
1	8171500	Main frame	1
2	8171000	Top Cover	1
3		See section "motor"	1
4		See section "blade shaft"	4
5		See section "secondary tensioning system"	1
6		See section "secondary tensioning system"	1
7		See section "primary tensioning system"	1
8	8171501	Lower cover	1
9	8171004	Inspection cover	1
10	8171502	Skid	1
11	8178002	Washer	6
12	8171506	Branch carrier	4
13+14	8174006	Belts	1
15	160141.0	Belt for motor	1
16	8178001	Plastic strip	1
17	8171504	Cover	1
18	8171505	Transport protection	1
19	8142002	Bolt	5
20	8222003	Washer	17
21	8172001	Bolt	4
22	8222009	Facet washer	4
23	1061042	Lock nut	2
24	8222008	Washer	2
25	8142004	Bolt	6
26	00.372.01	Split	4
27	8171503	Adapter "Option"	1
28	200104.0	Cover bolt	13
29	8142003	Washer	12
30	2770396	Bolt	12
31	8252006	Plade	2

Main frame PL

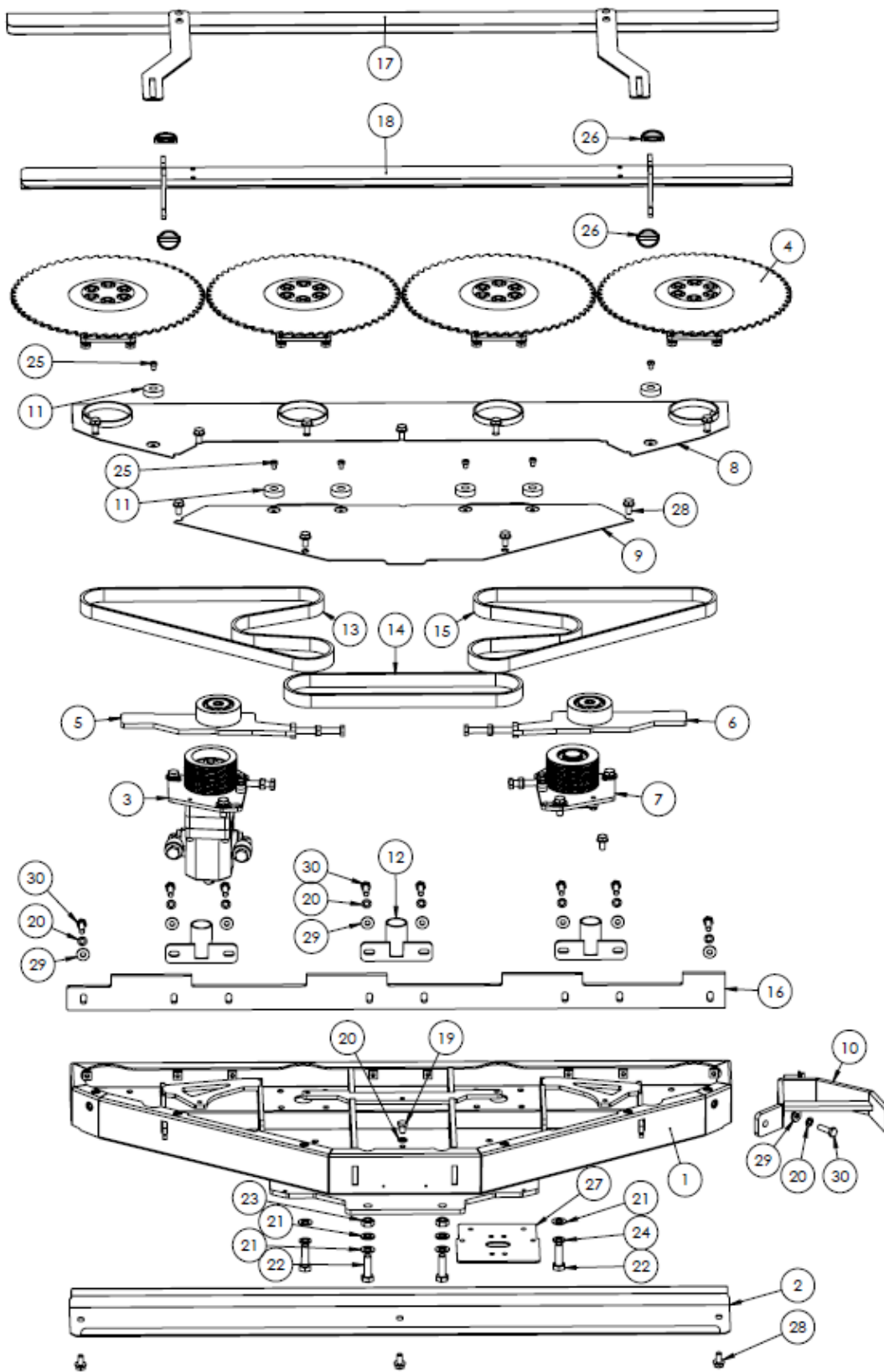

ITEM NO.	PART NUMBER	DESCRIPTION	QTY.
1	8171500	Main frame	1
2	8171000	Top Cover	1
3		See section "motor"	1
4		See section "blade shaft"	4
5		See section "secondary tensioning system"	1
6		See section "secondary tensioning system"	1
7		See section "primary tensioning system"	1
8	8171501	Lower cover	1
9	8171004	Inspection cover	1
10	8171508	Skid Private label	1
11	8178002	Washer	6
12	8171507	Branch carrier PL	3
13+15	8174006	Belts	1
14	160141.0	Belt for motot	1
16	8178001	Plastic strip	1
17	8171504	Cover	1
18	8171505	Transport protection	1
19	8142002	Bolt	5
20	8222003	Washer	17
21	8222009	Facetwasher	4
22	8222007	Bolt	4
23	1061042	Lock nut	2
24	8222008	Washer	2
25	8142004	Bolt	6
26	00.372.01	Split	6
27	8171503	Adapter "Option"	1
28	200104.0	Cover bolt	13
29	8142003	Washer	10
30	2770396	Bolt	10

Motor

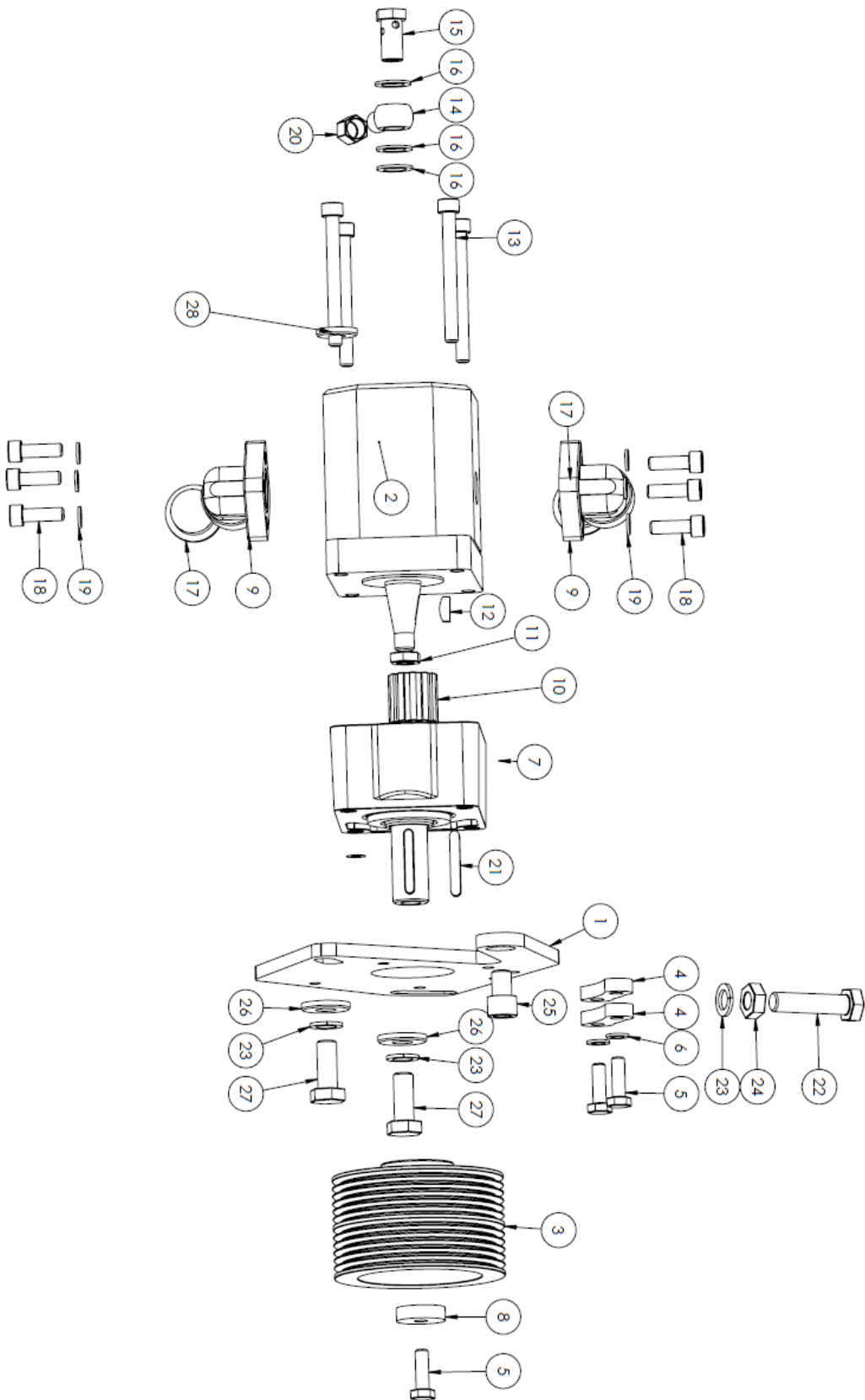

ITEM NO	PART NUMBER	DESCRIPTION	QTY
1	8171005	Adjuster plate RH see drawing	1
2	200130.0	Motor	1
	200160.0	Sealkit to 200130.0	
3	8174003	Pulley	1
4	8251010	Stop	2
5	200139.0	Bolt	3
6	200156.0	Washer	2
7	200131.0	Pulley support	1
8	200138.0	Pulley washer	1
9	200132.0	Port elbow	2
10	200133.0	Spline bushing	1
11	1021512	Nut (incl. pos 2)	1
12	1551004	Wedge (incl. pos 2)	1
13	8172006	Allen screw	4
14	8173001	Banjo	1
15	8173002	Banjo bolt	1
16	8173003	Bonded seals	3
17	Incl. pos 9	Plastic plug	2
18	Incl. pos 9	Bolt	6
19	Incl. pos 9	Washer	6
20	Incl. pos 14	Plastic plug	1
21	200134.0	Key (incl pos. 7)	1
22	8172001	Bolt	1
23	8222005	Washer	3
24	2770536	Nut	1
25	8222014	Bolt	1
26	8222011	Washer	2
27	8222006	Bolt	2
28	200156.0	Springwasher	4

Blade shaft

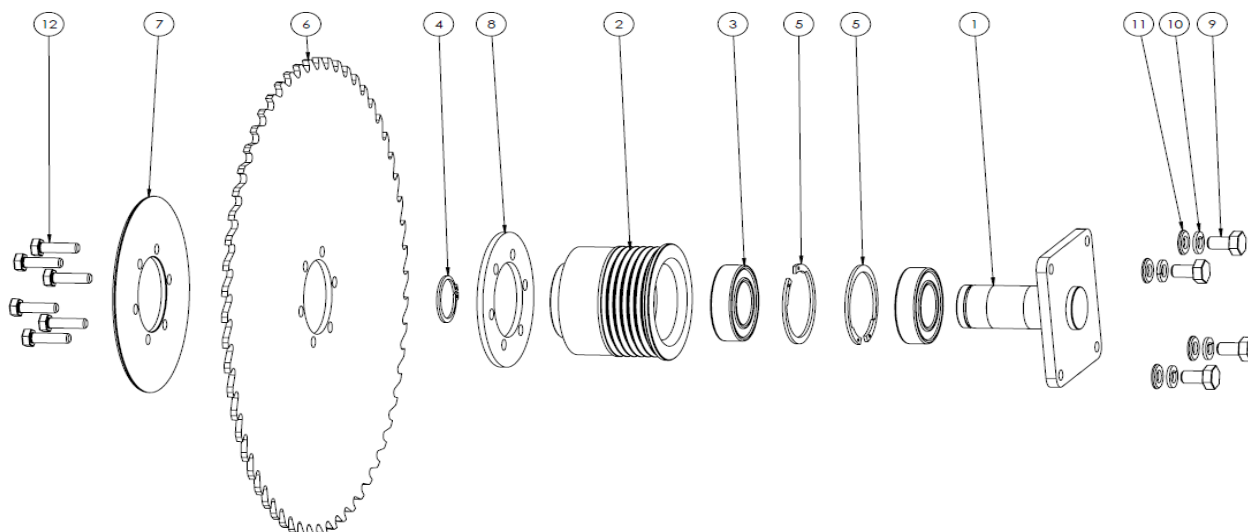

ITEM NO.	PART NUMBER	DESCRIPTION	QTY.
1	8171003	Spindle	1
2	8174002	Pulley	1
3	8174001	Bearing	2
4	0162001.0	Loch ring	1
5	200119.0	Loch washer	2
6	8177001	Saw blade Ø390	1
Not shown		Wooden transportbox for 4 sawblades	1
7	8171001	Mounting plate	1
8	8171002	Dust plate	1
9	8142002	Bolt	4
10	8222003	Loch washer	4
11	2770436	Washer	4
12	8172005	Bolt	6

Qty. er antal forbrug pr. aksel.
 Qty. ist Anzahl an jeder Welle.
 Qty. is no. for each Shaft.

Option Bladerotor kpl. OPTE 4227

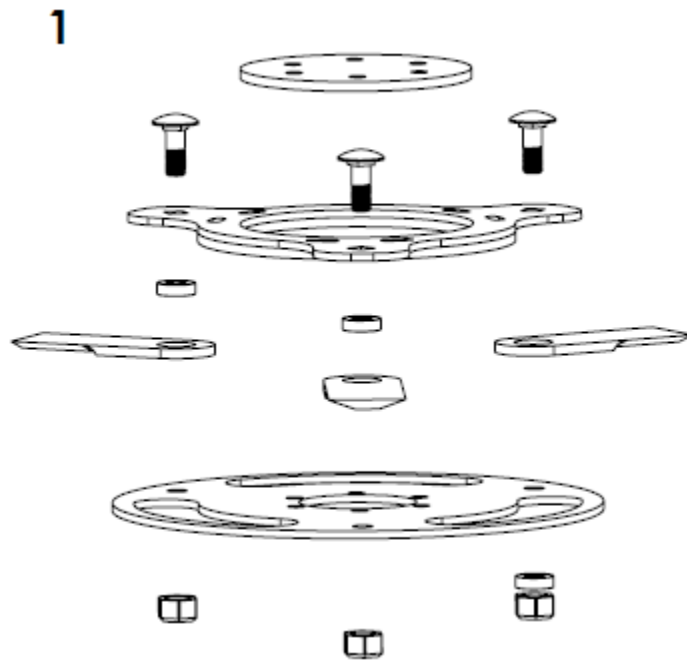

ITEM NO.	PART NUMBER	DESCRIPTION	QTY.
1	8171510	Rotor cpl.	4
NS	8177009	Plastic strip	1
3	8021502	Tool for blade change	1

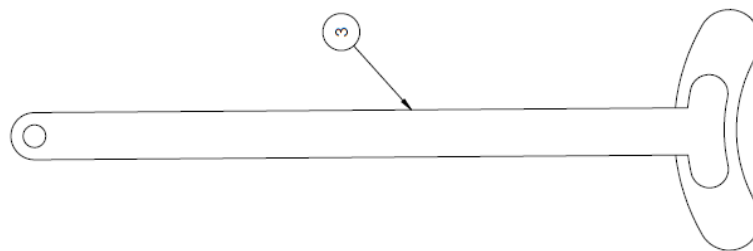

Secondary tensioning system

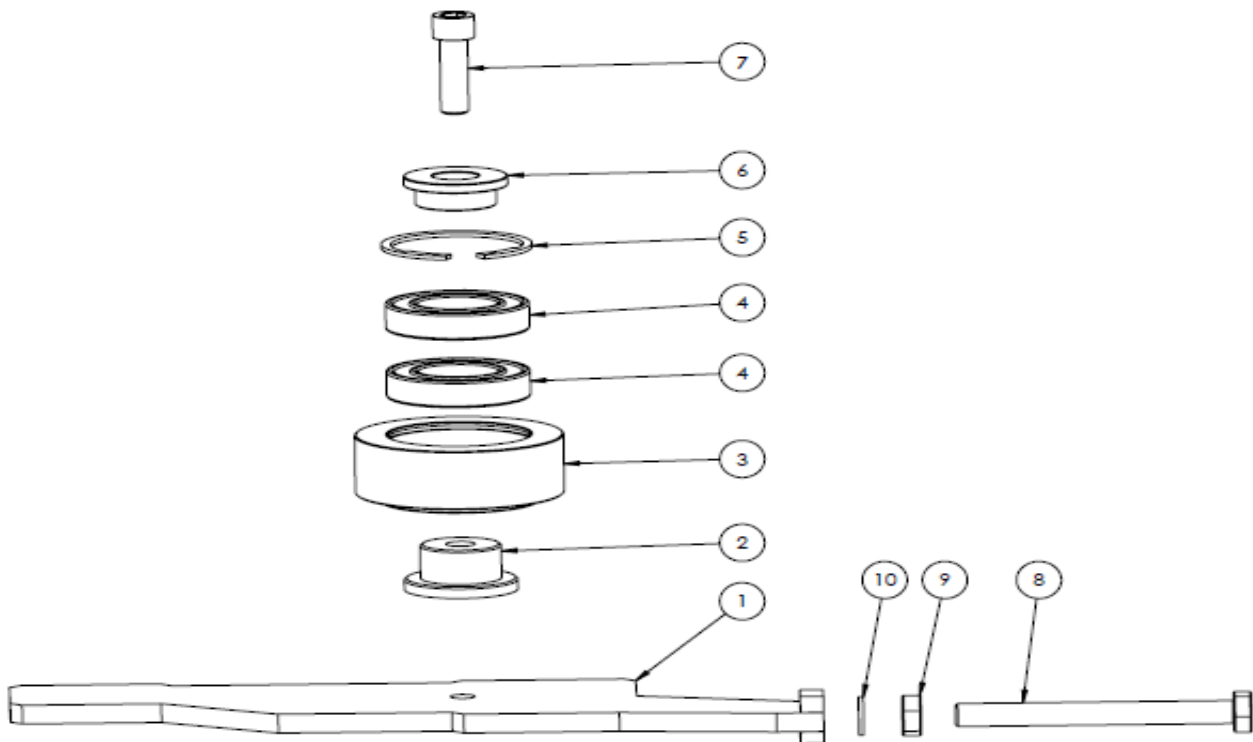

ITEM NO.	PART NUMBER	DESCRIPTION	QTY.
1	8171509	Adjuster fork	1
2	8171007	Shaft	1
3	8174004	Tensioner wheel	1
4	8174001	Bearing	2
5	200119.0	Locking ring	1
6	8171008	Washer	1
7	8172003	Bolt	1
8	8362007	Adjuste bolt	1
9	2770536	Nut	1
10	8222005	Lock washer	1

2 stk pr. maskine.
 2 stück an jeder Maschine.
 2 pcs per machine.

Primary tensioning system

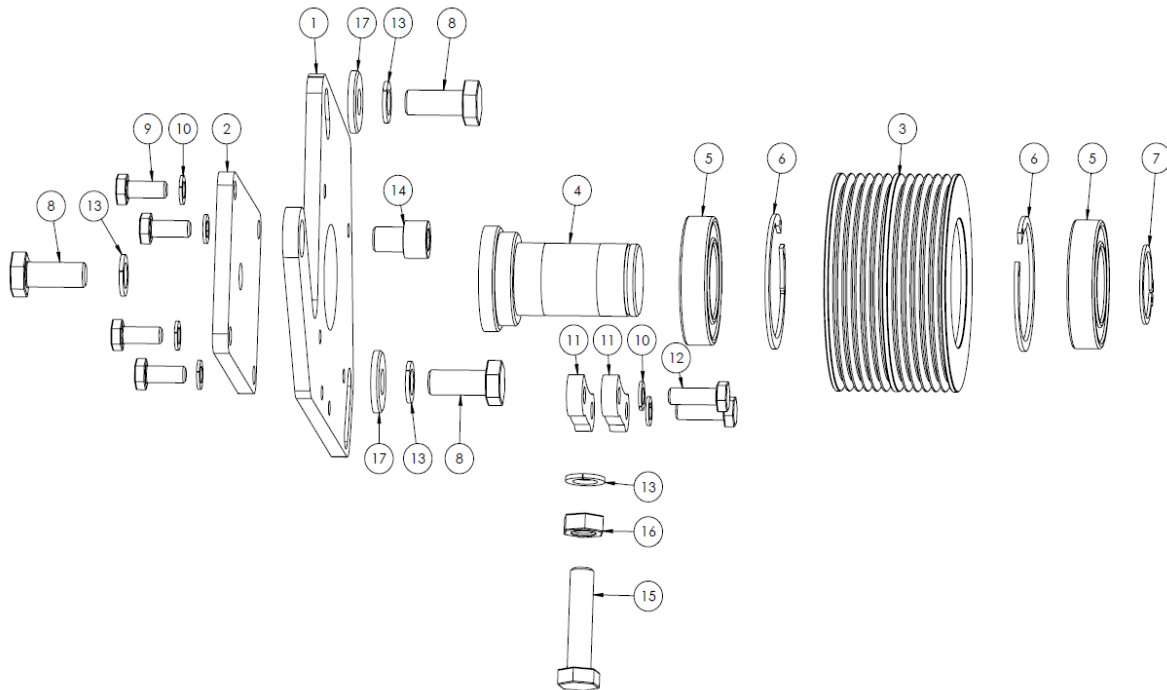

ITEM NO.	PART NUMBER	DESCRIPTION	QTY.
1	8171005	Adjuster plate RH/LH	1
2	8171009	Blanking cover	1
3	8174005	Pulley	1
4	8171010	Spindle	1
5	8174001	Bearing	2
6	200119.0	Locking ring	2
7	0162001.0	Locking ring	1
8	8222006	Bolt	3
9	2770402	Bolt	4
10	200156.0	Washer	6
11	8251010	Stop	2
12	200139.0	Bolt	2
13	8222005	Washer	4
14	8222014	Bolt	1
15	8172001	Bolt	1
16	2770536	Nut	1
17	8222011	Washer	2
Not shown	200155.0	Tool for belt tension control "optikrik II"	1

Stickers



LRS1602 advarselsmærker - 325 x 56 mm



LRS1602 advarselsmærker2 - 325 x 56 mm

HØJRE



LRS1602 klistermærke_top - 210 x 100 mm

VENSTRE



LRS1602 klistermærke_top - 210 x 100 mm



GreenTec_Påbudsmærker - 130 x 25 mm

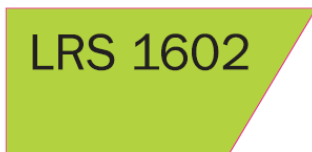

LRS1602 klistermærke_bund - 210 x 100 mm

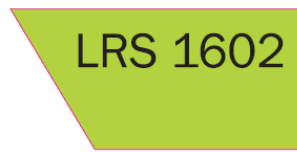

LRS1602 klistermærke_bund - 210 x 100 mm



Made in denmark - 50 x 16 mm

LRS1602 KITS

ITEM NO.	PART NUMBER	DESCRIPTION	QTY.
1	LRS1602KITS	Transfers cpl. kit	1



Merkurvej 25 | DK-6000 Kolding | Tel.: +45 75 55 36 44 | info@GreenTec.eu | www.GreenTec.eu

Cutting Edge Technology